





This datasheet describes the use of the MP-7217 Pellistor. This is commonly used, but not exclusively, in mining applications. It is a low power, intrinsically safe, extremely robust and poison-resistant device in a certified flameproof enclosure.

The MP-7217 has been designed to provide the basic sensor performance that will enable a suitable instrument to meet the various (Group 1) mining performance standards. The MP-7217, whilst being optimised for its methane response (up to 5% volume in air), will also detect other flammable gases and vapours. For further information, contact SGX Sensortech.

FEATURES

- Low power – designed for battery operation
- Small size (14.4 x 6.7 mm)
- Compatible with VQ500 head instrument
- High resistance to mechanical shocks
- Low orientation effect
- ATEX/IECEx certified package
- The certification markings are:

 II 1G Ex ia IIC Ga and  I M1 Ex ia I Ma

 II 2G Ex d IIC Gb and  I M2 Ex d I Mb

OPERATING PRINCIPLE

The silicon pellistor structure consists of a pair of accurately micro machined diaphragms with two embedded planar heater meanders coated with a layer incorporating a noble metal catalyst for Detector device and with inert layer for Compensator device.

The meander acts both as an electrical heater and as a resistance thermometer. The device is mounted on a PCB with wire bonding and is surrounded by a plastic can with the end open to the atmosphere. If a flammable gas is present when the device is heated to about 400 – 500 °C, the gas will oxidise and the resultant release of energy will heat the device still further. This increase in temperature is detected as an increase in resistance of the meander. The temperature of the meander is also affected by ambient temperature and by variations in thermal conductivity of the air caused by the possible presence of inert gases such as carbon dioxide. To compensate for temperature changes not caused by the oxidation of the flammable gas a second, inert device is used. This compensator is made in the same way as a detector device except that instead of incorporating a catalyst in the coating layer, the device is treated so that oxidation cannot take place. The two devices are then used in a circuit that detects the difference in their resistances. Since the two devices are generally of a different colour, they have different emissivities and hence different slope resistances. Therefore, to obtain the best temperature performance, it is necessary on occasion to connect a fixed resistor in parallel with the compensator to correct for its higher slope resistance.

Whilst SGX Sensortech has taken care to ensure the accuracy of the information contained herein it accepts no responsibility for the consequences of any use thereof and also reserves the right to change the specification of goods without notice. SGX technologies accepts no liability beyond the set out in its standard conditions of sale in respect of infringement of third party patents arising from the use of tubes or other devices in accordance with information contained herein. In case of modification of the product, SGX disclaims all liability.

MP-7217 and VQ548MP MEMS Pellistor MP Series

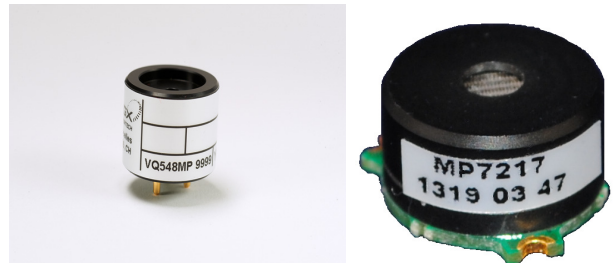

OPERATION

It is recommended that the detector and compensator be run in a Wheatstone bridge circuit.

A suitable circuit is shown below. In use, the bridge supply voltage should be stable to within + 0.05 V, or the output in clean air may change in sympathy. Although it is generally recommended that pellistors should be run with a constant voltage supply to the bridge, it is possible to use a constant current supply provided that the voltage across the bridge in clean air remains within the recommended limits.

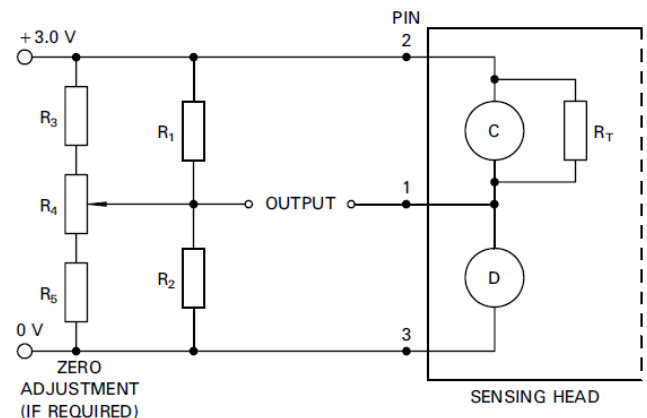

$$R_1 = R_2 = 500\Omega \text{ to } 10 \text{ k}\Omega$$

$$R_3 = R_5 \approx 10R_1$$

$$R_4 \approx 20R_1$$

Recommended circuit diagram

SENSOR CONFIGURATION

The internal connections are shown below.

Pin	Connection
1	Output
2	Compensator
3	Detector

2 and 3 are the two pins of the dual device MEMS pellistor (purely ohmic resistors, not polarized)

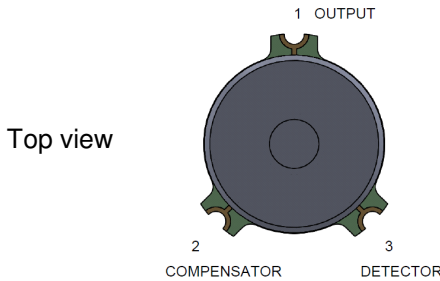

A variant is available as a replacement for 3 Volt , 20 mm diameter, certified head sensors such as the VQ548ZD pellistor. The sensor is mounted onto pin holder socket and placed in a plastic head with the same VQ500 head dimensions.

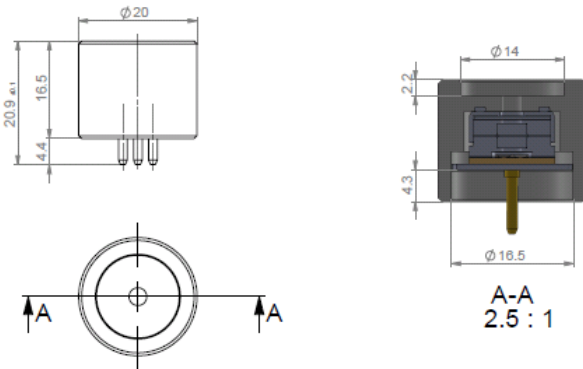

GENERAL DATA

This information relates to the device operating continuously in the recommended bridge circuit

Gases detected most flammable gases and vapours

Operation continuous

Bridge supply voltage (see note 1) 2.9 to 3.1V

Sensor current (at 3.0 ± 0.1V) 39 to 41 mA

Minimum sensitivity (measured with 1% methane, 20% LEL, at 3.0 ± 0.1V) 12 mV/% methane

Zero offset range in clean air (at 3.0 ± 0.1V) ± 20 mV max

Response time (t90) (see note 2) < 12 seconds

Maximum gas concentration (see note 3) 5% methane in air

Long Term Zero drift (see note 4) < 1.0 mV/month

Long Term Sensitivity drift (see note 5) < 0.6 mV/month

MAXIMUM RATINGS (Absolute values)

Input voltages between pins:
 pins 2 and 3 3.2 V
 pins 1 and 2 1.6 V
 pins 1 and 3 1.6 V

Operation, storage in original packaging and shipping:
 Temperature -40 to +60 °C
 (certified -40 to +75 °C for intrinsic safety)

Humidity 0 to 95%RH non-condensing

NOTES

1. The polarity of the supply voltage may be reversed without harm. The only effect is to reverse the polarity of the output signal.
2. Measured at 3.0 ± 0.1 V using 1% methane in an SGX test manifold.
3. Exceeding these limits may degrade the stability of sensitivity or zero offset. The calibration of the sensor should be checked if it has been exposed, whilst operating, to gas concentrations greater than the Lower Explosive Limit.
4. Over 90 days period.
5. Measured at 3.0 ± 0.1 V using 1% methane, over 90 days period.

IMPORTANT PRECAUTIONS

Read the following instructions carefully before using the MP-7217 described in this document to avoid erroneous readings and to prevent the device from permanent damage.

- Heater voltages above the specified maximum rating can damage the MEMS Pellistor.
- Some compounds are known to affect the catalytic reaction of coating material used in pellistors.
 - I. Exposure to silicones (by far the most common & virulent poison), high levels of hydrogen sulfide (and other sulfur containing compounds), phosphates and phosphorous containing substances or lead containing compounds (especially tetraethyl lead) will irreversibly poison the sensor. High concentrations of flammable gas may also permanently affect the sensor response.
 - II. Lower concentrations of Hydrogen sulfide and other compounds can cause a temporary loss in response. This is known as inhibition. Halogenated hydrocarbons (Freon, trichloroethylene, methylene chloride, etc.), trichloroethane and methylene chloride are also possible inhibitors. The Sensors generally recover most of original response once they are returned to fresh air.
 - III. Specific protection may be needed in applications where poisons or inhibitors are continuously present.
- SGX recommends using ESD protection equipment when handling the sensor.
- For any additional questions, contact SGX.

PACKAGE OUTLINE DIMENSIONS

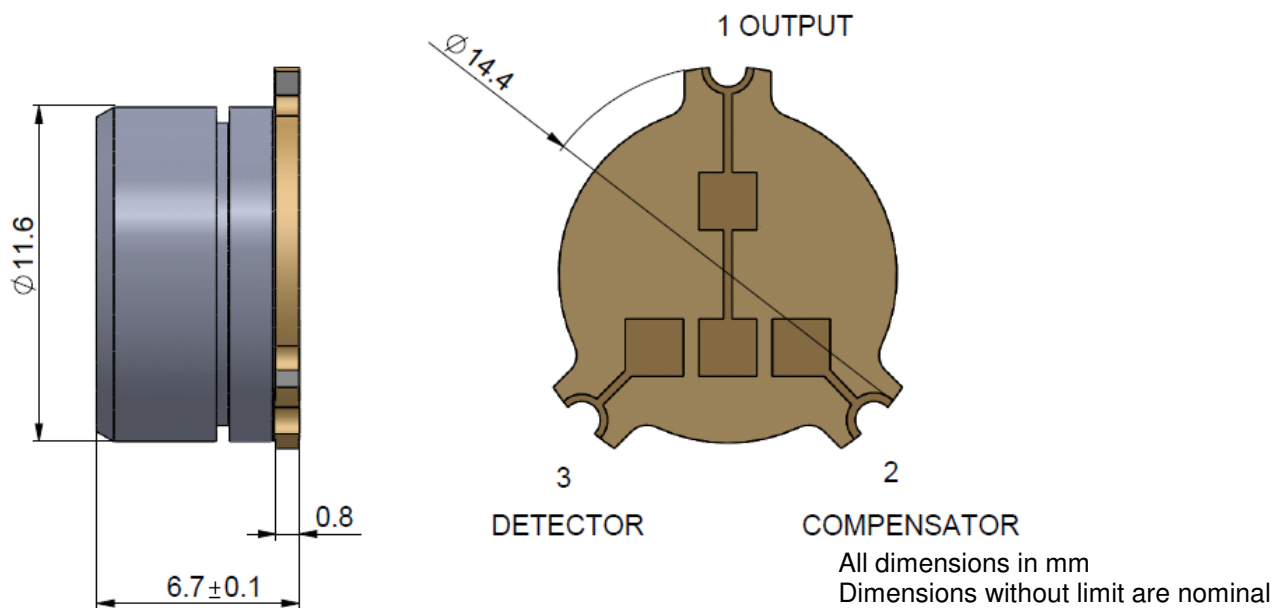

VQ500-MP HEAD OUTLINE

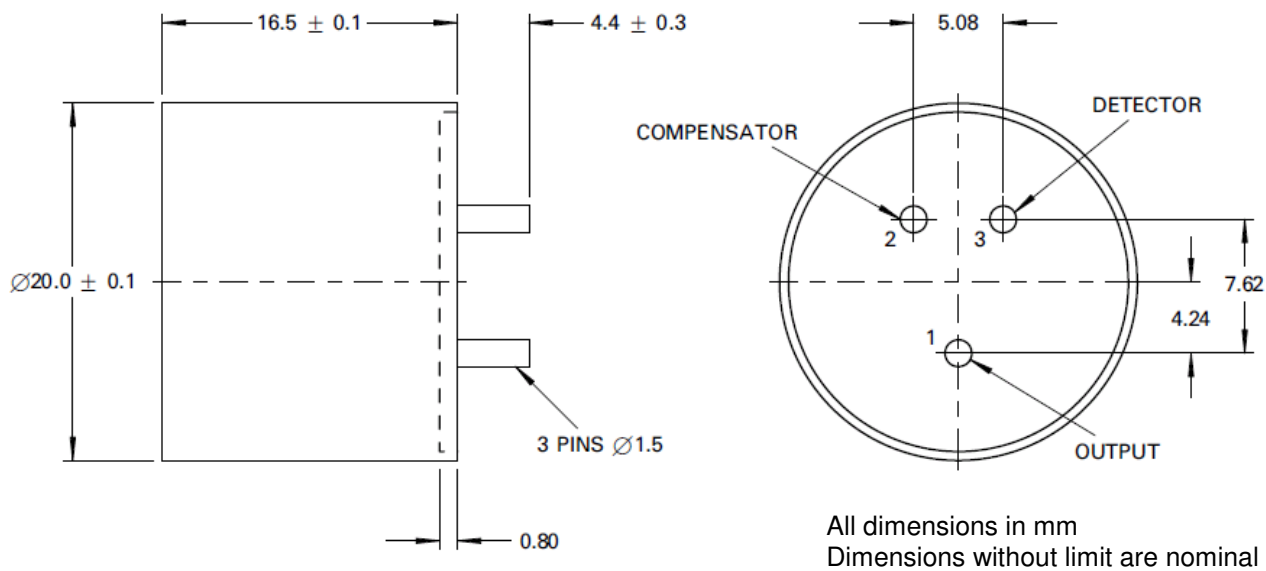

INSTRUCTIONS SPECIFIC TO HAZARDOUS AREA INSTALLATIONS

(Ref EU ATEX Directive 94/9/EC, Annex II, 1.0.6)

1. The MP-7217 and VQ548MP Gas Sensor is component approved only and may not be used as a stand-alone item in a hazardous area without further protection.
2. The component is only certified for operation in ambient temperatures between -40°C and $+60^{\circ}\text{C}$ and should not be used outside this range. For intrinsic safety the component is certified for operation in extended ambient temperatures between -40°C and $+75^{\circ}\text{C}$.
3. For the purpose of temperature classification of the apparatus in which the MP-7217 Series Gas Sensor is used, the maximum temperature rise on any external surface does not exceed 67°C for an ambient of $+60^{\circ}\text{C}$. This value is lower for VQ548MP device because of the larger radiating surface.
4. The MP-7217 and VQ548MP Gas Sensor shall be used in conjunction with apparatus providing an intrinsically safe supply having a maximum output power (PO) not greater than 1.1 W.
5. When this component is utilized in equipment that is intended to be used in group I applications, it shall be suitably protected to ensure that it will withstand an impact energy in excess of the 7 J low risk of impact value specified in EN60079-0: clause 26.4.
6. The MP-7217 and VQ548MP Gas Sensor has not been assessed as a safety device (EHSR 1.5).
7. There are no user-serviceable parts in the component.

8. The end-user/installer should be aware that the certification of the MP-7217 and VQ548MP Gas Sensor relies on the following materials used in its construction, which are suitable for most common applications:

Enclosure PEI-ULTEM 1000

Mesh Flame Arrestor Stainless Steel

In accordance with the Note in EN60079-0:Clause 6.1(a), the end-user/installer shall inform the manufacturer of any adverse conditions that the MP-7217 and VQ548MP Gas Sensor may encounter. This is to ensure that the MP-7217 and VQ548MP Gas Sensor are not subject to conditions that may cause degradation of these materials.

9. The certification markings for the MP-7217 and VQ548MP Gas Sensor are:

Ex II 1G Ex ia IIC Ga and Ex I M1 Ex ia I Ma; in compliance with EN60079-0: 2012, EN60079-11: 2012
LCIE 13 ATEX 3064 U
 $U_i \leq 6.0\text{V}$, $I_i \leq 185\text{mA}$, $P_i \leq 1100\text{mW}$, $C_i=0$, $L_i=0$,
Ambient temperature: -40°C to $+75^{\circ}\text{C}$

Ex II 2G Ex d IIC Gb and Ex I M2 Ex d I Mb; in compliance with EN60079-0: 2012, EN60079-1: 2007
LCIE 13 ATEX 3065 U
Rated voltage: 2.9 to 3.1 V
Rated current: 39 to 41 mA
Power: $< 150\text{mW}$
Ambient temperature: -40°C to $+60^{\circ}\text{C}$