

## Product Datasheet

# Laser Gas Detection OEM Module LGD F200P2-H Series

## 1 General description

**Axetris** is offering Laser Gas Detection (LGD) modules with exceptional advantages and value for the customer. Tunable Diode Laser Spectrometry (TDLS), enhanced by proprietary technology, is used for the measurement of CO<sub>2</sub>, NH<sub>3</sub>, CH<sub>4</sub>, HCl, (H<sub>2</sub>O). The modules are designed for integration by Original Equipment Manufacturers (OEMs), active in the field of gas detection and monitoring in diverse industries.

The **LGD F200** series is based on a contactless, near-infrared absorption measurement of the target gas. The systems are self-contained, ready-to-use OEM modules, using a flow-through cell set-up for extractive measurements. The slightly bigger LGD F200 (H) version features optional cell heating up to 220°C for hot gas measurements in process control and environmental compliance related applications.

The system has micro-processor-driven read-out electronics and digital and/or analog data outputs for industry-standard connectivity. Proprietary electronic lock-in technology allows separating gas absorption information from electro-optical system information, eliminating the need for a physical reference channel and providing continuous sensor status monitoring. Low maintenance operation and long life time provide customers with exceptionally low cost-of-ownership and make the LGD F200 the ideal instrument for your OEM applications.

### Main applications

- Process control:  
SCR, incineration & combustion processes, ...
- Emission monitoring:  
Power generation, engine development, waste incineration furnaces, ...
- Environmental monitoring:  
Landfill & green-house gases, livestock, ...
- Chemical engineering:  
Production control & monitoring ...
- Safety:  
Leak detection, refrigeration, toxic gases, ...
- Climate control & monitoring:  
Livestock, climate chambers & rooms, ...



### Key features

- Made for easy integration by OEMs
- Optical, contact-less measurement
- Accurate laser-diode electro-optics
- High selectivity
- Fast response
- Self-contained
- Continuous sensor status monitoring
- Low maintenance
- Low cost-of-ownership
- 10-30V power supply
- Digital and analog data interfaces
- Hot-gas measurement up to 170/190/220°C

## 2 Execution specifications

### 2.1 Gas detection specifications for LGD F200P2-H NH<sub>3</sub> SCR Industrial

Important:

Reference conditions: External: 20°C – 23°C, 920 -1020 hPa, 40 to 50% r.H.; Gas & cell: Incoming gas temperature at 190°C, measurement cell at 190°C/220°C, 10% absolute H<sub>2</sub>O in the measurement gas.

Parameter	Unit	Value / Range
Gas	-	NH <sub>3</sub>
Maximum Range	ppm	0 – 100
Minimum Range	ppm	0 – 20
		calibration to full scale (FS) range, standard is 100 ppm, for safety reasons max. calibration to 100 ppm (linearity up to 500 ppm, no warranty of precision)
Accuracy <sup>1</sup>	-	± 2.0 % full scale reading depending on integration stability (temperature & pressure)
Precision <sup>2</sup> 2σ	ppm	1.8 with 1 s averaging time <sup>3</sup> 0.8 with 10 s averaging time <sup>3</sup>
Linearity & Repeatability	-	included in the accuracy
Gas cross talk/interference	-	to H <sub>2</sub> O: < 0.05 ppm of reading NH <sub>3</sub> per % H <sub>2</sub> O
Displayed resolution	ppm	0.01 (negative values can also be displayed)
Refresh rate	s	1 (integration time can be selected, max. 600 s)
T <sub>90</sub> time	s	2 (at gas flow rate of 3 L/min)
Recommended stabilized Integration Temperature	°C	20 ... 45 (as narrow as possible, application defined)
Cell temperature range	°C	190/220
Incoming gas temperature	°C	same as set cell temperature
Max. surface temp. housing	°C	65 (@190°C) / 75 (@220°C)
Meas. gas max. humidity	% abs. H <sub>2</sub> O	30
Input for external parameter compensation	-	pressure, temperature or matrix gas concentration (optional)

<sup>1</sup> **Accuracy:** The accuracy is defined as the difference between the mean response during a 2 min time interval and the reference value at reference conditions. Variations of the operating temperature and pressure can affect the accuracy of the system.

<sup>2</sup> **Precision:** The precision is defined as 2 times the standard deviation σ of a 2 min measurement at stable reference conditions over the full measuring range. The precision of the system can be improved by mean of averaging.

<sup>3</sup> **Averaging time:** An exponential moving average (EMA) is applied on measured concentration values. The averaging time expresses the period of time of past measurements considered to compute the next averaged value. The averaging time can be set up to 600 s.

## 2.2 Gas detection specifications for LGD F200P2-H NH3 QAL1 compliant

Important:

Reference conditions: External: 20°C – 23°C, 920 -1020 hPa, 40 to 50% r.H.; Gas & cell: Incoming gas temperature at 190°C, measurement cell at 190°C, 10% absolute H<sub>2</sub>O in the measurement gas.

Parameter	Unit	Value / Range
Gas	-	NH <sub>3</sub> / H <sub>2</sub> O
NH <sub>3</sub>	ppm	
Minimum Range		0 – 15
Extended Range		0 – 50
H <sub>2</sub> O	% vol.	
Minimum Range		0 – 30
Maximum Range		0 – 40
Accuracy <sup>1</sup>	-	± 2.0 % full scale reading depending on integration stability (temperature & pressure)
NH <sub>3</sub> Precision <sup>2</sup> 2σ	ppm	0.2 with 60 s averaging time <sup>3</sup>
H <sub>2</sub> O Precision <sup>2</sup> 2σ	ppm	1000 with 60 s averaging time <sup>3</sup>
Linearity & Repeatability	-	included in the accuracy
Cross-sensitivity NH <sub>3</sub>	-	< 4.0 % (15% vol. H <sub>2</sub> O)
Cross-sensitivity H <sub>2</sub> O		< 4.0 % (15% vol. CO <sub>2</sub> , 21% vol.O <sub>2</sub> )
Displayed resolution	ppm	0.01 (negative values can also be displayed)
Refresh rate	s	2 (integration time can be selected, max. 600 s)
T <sub>90</sub> time	s	10 (at gas flow rate of 3 L/min)
Recommended stabilized Integration Temperature	°C	20 ... 45 (as narrow as possible, application defined)
Cell temperature range	°C	190
Incoming gas temperature	°C	same as set cell temperature, max. 190
Max. surface temp. housing	°C	65
Input for external parameter compensation	-	pressure, temperature or matrix gas concentration (optional)

<sup>1</sup> **Accuracy:** The accuracy is defined as the difference between the mean response during a 2 min time interval and the reference value at reference conditions. Variations of the operating temperature and pressure can affect the accuracy of the system.

<sup>2</sup> **Precision:** The precision is defined as 2 times the standard deviation  $\sigma$  of a 2 min measurement at stable reference conditions over the full measuring range. The precision of the system can be improved by mean of averaging.

<sup>3</sup> **Averaging time:** An exponential moving average (EMA) is applied on measured concentration values. The averaging time expresses the period of time of past measurements considered to compute the next averaged value. The averaging time can be set up to 600 s.

## 2.3 Gas detection specifications for LGD F200P2-H NH3 SCR Vehicle

Important:

Reference conditions: External: 50°C, 920 -1020 hPa, 40 to 50% r.H.; Gas & cell: Incoming gas temperature at 170°C, measurement cell at 170°C, 10% absolute H<sub>2</sub>O in the measurement gas.

Parameter	Unit	Value / Range
Gas	-	NH <sub>3</sub>
Principle of detection	-	Tunable Diode Laser Spectrometry (TDLS)
Range	ppm	0 – 1500 Standard calibration is 100 ppm, for safety reasons
Accuracy <sup>1</sup>	-	± 1 ppm (0-99ppm) +/-1% of Reading (100 – 999ppm) +/- 3% of Reading (1000 – 1500ppm)
Lower Detection Limit <sup>2</sup>	ppm	1 with 1 s averaging time <sup>3</sup>
Precision <sup>4</sup> 2σ	ppm	1.8 or 1% of Reading, whichever is larger with 1 s averaging time <sup>3</sup>
Linearity & Repeatability	-	included in the accuracy
Gas cross talk/interference	-	to H <sub>2</sub> O: < 0.05 ppm NH <sub>3</sub> per % H <sub>2</sub> O
Displayed resolution	ppm	0.01 (negative values can also be displayed)
Refresh rate	s	1 (integration time can be selected, max. 600 s)
T <sub>90</sub> time	s	2 (at gas flow rate of 3 L/min)
Recommended stabilized Integration Temperature	°C	25 ... 50 (as narrow as possible, application defined)
Cell temperature range	°C	170
Incoming gas temperature	°C	same as set cell temperature
Max. surface temp. housing	°C	60
Meas. gas max. humidity	% abs. H <sub>2</sub> O	40
Input for external parameter compensation	-	pressure, temperature or matrix gas concentration (optional)

<sup>1</sup> **Accuracy:** The accuracy is defined as the difference between the mean response during a 2 min time interval and the reference value in dry conditions. Variations of the operating temperature and pressure can affect the accuracy of the system.

<sup>2</sup> **Lower Detection Limit:** The LDL is defined as 2 times the standard deviation  $\sigma$  of a 2 min measurement at stable reference conditions 0ppm setpoint. It can be improved by mean of averaging.

<sup>3</sup> **Averaging time:** An exponential moving average (EMA) is applied on measured concentration values. The averaging time expresses the period of time of past measurements considered to compute the next averaged value. The averaging time can be set up to 600 s.

<sup>4</sup> **Precision:** The precision is defined as 2 times the standard deviation  $\sigma$  of a 2 min measurement at stable reference conditions at full scale. The precision of the system can be improved by mean of averaging.

## 2.4 Gas detection specifications for LGD F200P2-H H2O

Important:

Reference conditions: External: 20°C – 23°C, 920 -1020 hPa, 40 to 50% r.H.; Gas & cell: Incoming gas temperature at 190°C, measurement cell at 190°C, 10% absolute H<sub>2</sub>O in the measurement gas.

Parameter	Unit	Value / Range
Gas	-	H <sub>2</sub> O
Principle of detection	-	Tunable Diode Laser Spectrometry (TDLS)
Range	% vol.	0 – 30 calibration to full scale (FS) range
Accuracy <sup>1</sup>	% vol.	± 0.5 absolute, depending on integration stability (temperature & pressure)
Precision <sup>2</sup> 2σ	% vol.	0.2 with 1 s averaging time <sup>3</sup> 0.1 with 10 s averaging time <sup>3</sup>
Linearity & Repeatability	-	included in the accuracy
Displayed resolution	ppm	0.01 (negative values can also be displayed)
Refresh rate	s	1 (integration time can be selected, max. 600 s)
T <sub>90</sub> time	s	2 (at gas flow rate of 3 L/min)
Recommended stabilized Integration Temperature	°C	20 ... 45 (as narrow as possible, application defined)
Cell temperature range	°C	190
Incoming gas temperature	°C	same as set cell temperature, max. 190
Max. surface temp. housing	°C	65
Meas. gas max. humidity	% abs. H <sub>2</sub> O	30
Input for external parameter compensation	-	pressure, temperature or matrix gas concentration (optional)

<sup>1</sup> **Accuracy:** The accuracy is defined as the difference between the mean response during a 2 min time interval and the reference value at reference conditions. Variations of the operating temperature and pressure can affect the accuracy of the system.

<sup>2</sup> **Precision:** The precision is defined as 2 times the standard deviation σ of a 2 min measurement at stable reference conditions over the full measuring range. The precision of the system can be improved by mean of averaging.

<sup>3</sup> **Averaging time:** An exponential moving average (EMA) is applied on measured concentration values. The averaging time expresses the period of time of past measurements considered to compute the next averaged value. The averaging time can be set up to 600 s.

## 2.5 Gas detection specifications for LGD F200P2-H HCl

Important:

Reference conditions: External: 20°C – 23°C, 920 -1020 hPa, 40 to 50% r.H.; Gas & cell: Incoming gas temperature at 190°C, measurement cell at 190°C, 10% absolute H<sub>2</sub>O in the measurement gas.

Parameter	Unit	Value / Range
Gas	-	HCl
Principle of detection	-	Tunable Diode Laser Spectrometry (TDLS)
Maximum Range	ppm	0 – 100
Minimum Range	ppm	0 – 50 calibration to full scale (FS) range, standard is 50 ppm, for safety reasons max. calibration to 100 ppm (linearity up to 500 ppm, no warranty of precision)
Accuracy <sup>1</sup>	-	± 2.0 % full scale reading depending on integration stability (temperature & pressure)
Precision <sup>2</sup> 2σ	ppm	0.5 with 10 s averaging time <sup>3</sup> 0.2 with 60 s averaging time <sup>3</sup>
Linearity & Repeatability	-	included in the accuracy
Gas cross talk/interference	-	to H <sub>2</sub> O: < 0.05 ppm of reading HCl per % H <sub>2</sub> O
Displayed resolution	ppm	0.01 (negative values can also be displayed)
Refresh rate	s	1 (integration time can be selected, max. 600 s)
T <sub>90</sub> time	s	20 (at gas flow rate of 3 L/min)
Recommended stabilized Integration Temperature	°C	20 ... 45 (as narrow as possible, application defined)
Cell temperature range	°C	190
Incoming gas temperature	°C	same as set cell temperature, max. 190
Max. surface temp. housing	°C	65
Meas. gas max. humidity	% abs. H <sub>2</sub> O	30
Input for external parameter compensation	-	pressure, temperature or matrix gas concentration (optional)

<sup>1</sup> **Accuracy:** The accuracy is defined as the difference between the mean response during a 2 min time interval and the reference value at reference conditions. Variations of the operating temperature and pressure can affect the accuracy of the system.

<sup>2</sup> **Precision:** The precision is defined as 2 times the standard deviation σ of a 2 min measurement at stable reference conditions over the full measuring range. The precision of the system can be improved by mean of averaging.

<sup>3</sup> **Averaging time:** An exponential moving average (EMA) is applied on measured concentration values. The averaging time expresses the period of time of past measurements considered to compute the next averaged value. The averaging time can be set up to 600 s.

## 2.6 Environmental conditions

Parameter	Unit	Value / Range
Usage	-	Interior use
Maximum operating temperature range	°C	15 ... 50
Operating humidity	% r.H.	0 ... 99, non-condensing
Operating pressure	mbar	800 ... 1100
Storage temperature	°C	-40 ... 80
Storage humidity	% r.H.	0 ... 99, non-condensing
Emission level L <sub>pa</sub> *	dB	<70

\*specification for CE conformity

## 2.7 Mechanical characteristics

Parameter	Unit	Value / Range
Measurement cell	-	Flow-through set-up
Standard cell length	mm	200
Standard cell volume	mL	15
Maximum measurement gas flow rate (Minimum)	mL / min	5'000 (1'500)
Dimensions housing, heated (H) version:	mm <sup>3</sup>	380 x 122 x 78
Approx. weight, heated (H) version	kg	3.3
Inlet / outlet connectors, measurement gas	mm	6 O.D., Swagelok
Inlet / outlet connectors, purge gas (optional)	mm	6 O.D., push-in fitting

## 2.8 Electrical characteristics

Parameter	Unit	Value / Range
Voltage supply DC Min. / Max. rating	V	10 ... 30 (max. ripple ± 100mV, max. current 0.5A, DC inrush current limitation 1A, reverse battery protection)
System power consumpt.	W	< 2
Max. cell heating power consumption, (H) version	W	100
Start-up time	s	30
Warm-up time		
Cell heating to 190°C	min.	30 (starting at 25°C)
Cell heating to 220°C	min.	40 (starting at 25°C)
Stable operation after	min	60 (at 190°C cell temperature)

## 2.9 Communication interface

Parameter	Unit	Value / Range
Digital interface		
RS232	-	Protocol available; standard.
Analog interface		
Current output	mA	4...20, 12-bit resolution (on 0 ... 25 mA); standard
Voltage output	V	0...5, 12-bit resolution; on request
Alarm	-	Customer configurable and definable

## 3 Connector assignments

### 3.1 System Power / User interface connector assignments

**Figure 1:** Head view electronics housing. System Power / User interface terminal connector assignment.

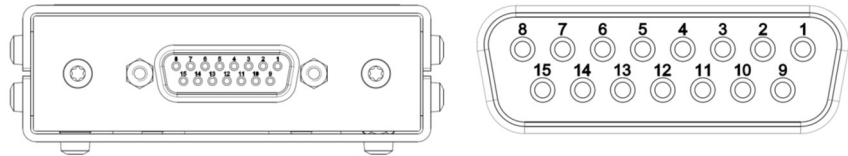

Connector assignment:

	Pin	Name	Description
Power Supply	1	POWER IN	Power supply 10 ... 30V
	2	GND IN*	Power supply ground
	3	SHIELD	DB 15 Connector - Housing
Digital Interfaces	6	GND*	Ground serial communication
	7	RS232 TX	UART serial communication
	8	RS232 RX	UART serial communication
	14	N/A	Not used
	15	N/A	Not used
Relay Alarms	4	ALARM 1	On/Off signal at defined conditions for relay control, hardware watchdog, etc
	5	ALARM 2	On/Off signal at defined conditions for relay control, hardware watchdog, etc
	11	ALARM 3	HW watchdog, firmware error and warnings
	12	VCC RELAY	Relay power supply: 10 V < Vcc Relay < 30 V; max. 0.75 A
	13	GND*	Ground, relay alarms
Analog Interface	9	ANALOG GND*	Analog ground
	10	ANALOG OUT	Analog output Factory setting: output current (4-20mA); output voltage (0-5V) on request only

\* same potential



### 3.2 Measurement cell heater connector assignment

**Figure 2:** Cell heater screw terminal connector assignment. Head view electronics housing.

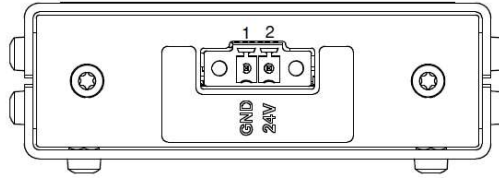

Connector assignment:

Pin	Name	Description
1	GND	Power ground
2	24V	Power supply 24V, Consumption: < 96W

## 4 Mechanical dimensions

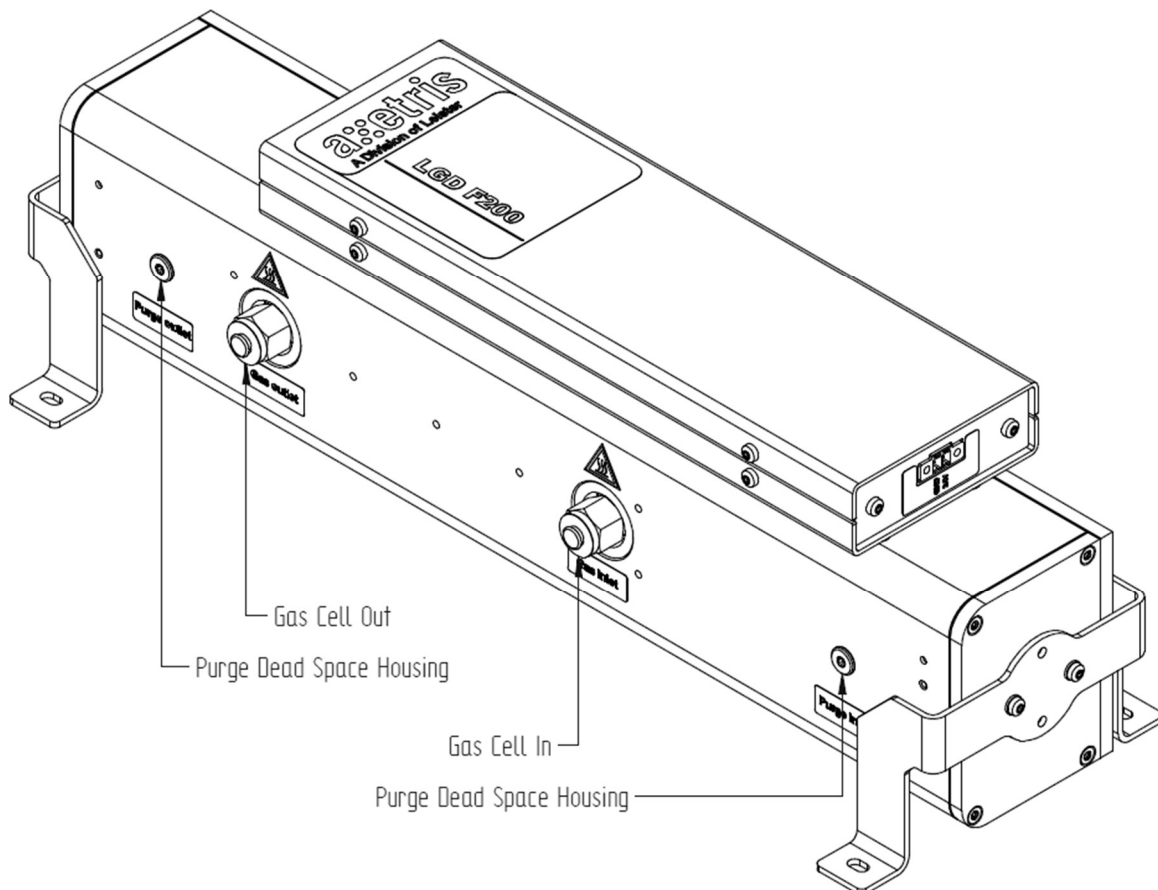

**Figure 3:** General view of the LGD F200P2 H sensor

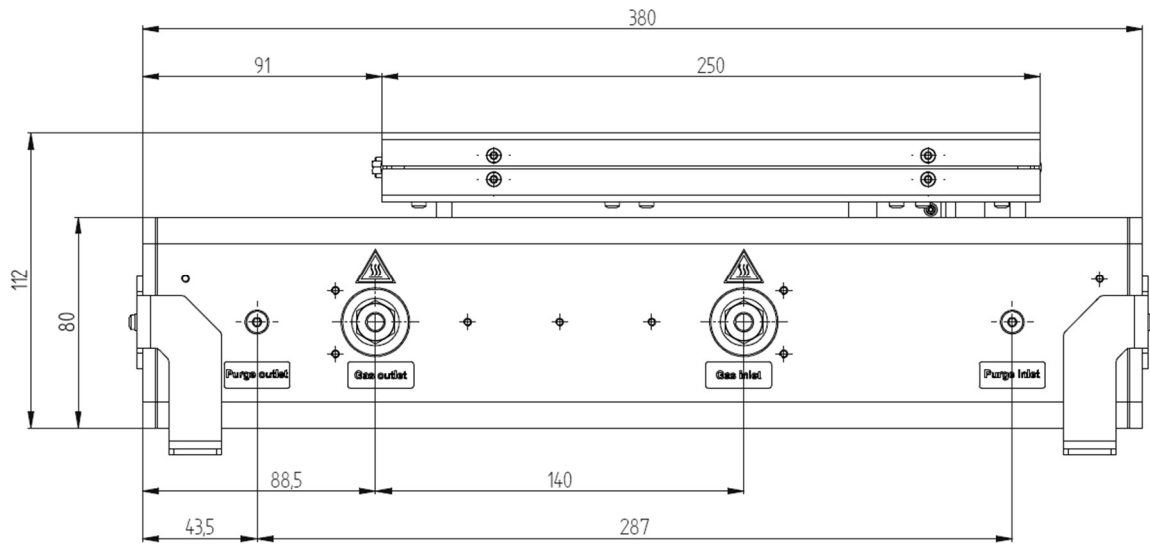

**Figure 4:** Side view, with gas connectors. Dimensions in mm

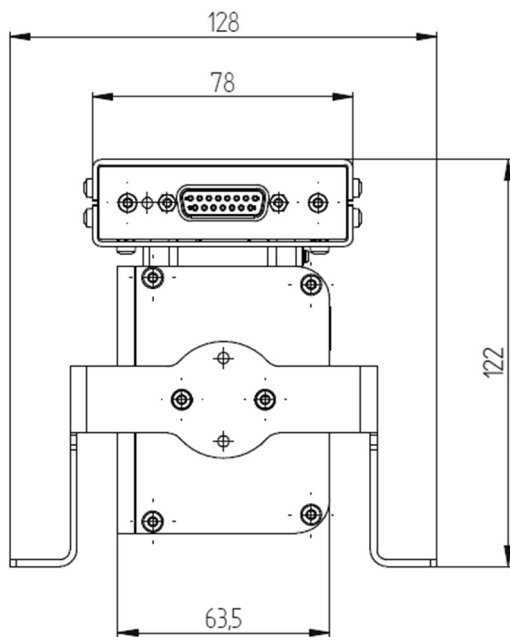

**Figure 5:** Front view. Dimensions in mm

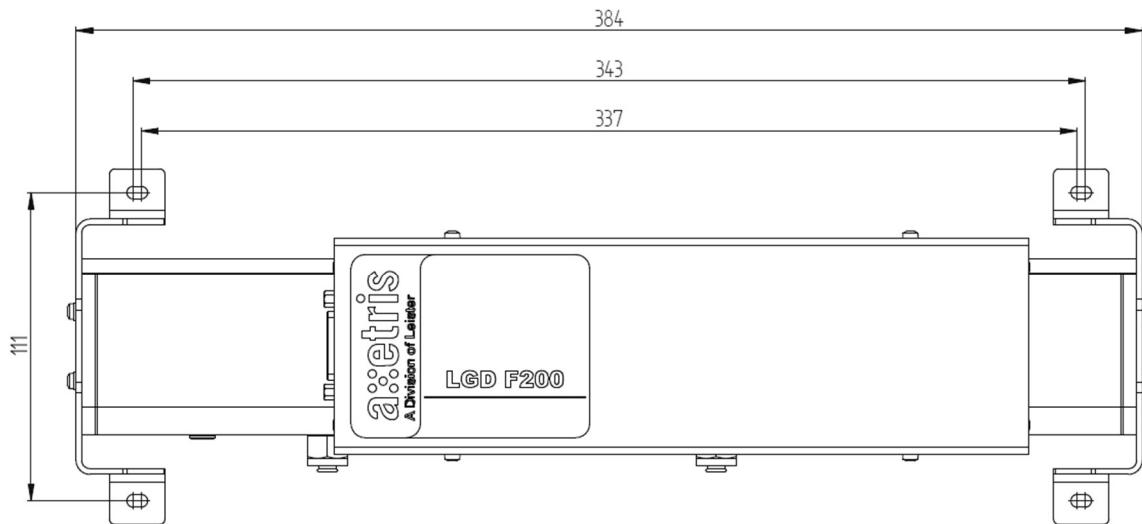

**Figure 6:** Top view. Dimensions in mm

## 5 Certifications

Type	Standard / Regulation	Limits
LGD F200P2 Platform conformity	REACH, CE	
Safety of laboratory products	EN/IEC 61010	
Safety of laser products	EN/IEC 60825-1	
EMC	EN/IEC 61326-1	Immunity test requirements for equipment intended for use in industrial locations
Shock	EN60068-2-27	150m/s <sup>2</sup> , half sinus, 11ms, max acceleration 15g, 18 cycles
Vibration	EN60068-2-6	5 ... 50Hz, amplitude 0.35mm, 1 octave /min, 2h per orientation (total 18 Frequency cycle)
Electronics conformity	RoHS / WEEE	

## 6 Caution

### 6.1 Product damage

- Read all instructions carefully before using the device.
- The LGD F200P2 H laser gas detection modules are calibrated for a particular gas and concentration range. Do not use the sensor outside of its specifications.
- The sensor is not suited for measuring gases with a dust load. The incoming measurement gas must be conditioned in order to avoid dust and condensation of liquid in the sensor. Gas loaded with particles or other substances can eventually contaminate the cell and make it necessary to service the instrument.
- The appliance must not be used in damp or wet surroundings.
- Use only accessories that are indicated in the instructions for use or are recommended by the manufacturer.
- Failure to comply with these instructions could result in product damage.

### 6.2 Danger of life

- The sensor must not be used with flammable or explosive gases or mixtures.
- Unprofessional gas handling can cause injury or death. The use of gas detection modules should only be performed by qualified personnel
- Do not use this product as safety or emergency stop device or in any other application where failure of the product could result in personal injury or death.

© 2019 AXETRIS AG – Company of the Leister Group

## Contact

**Headquarters:**  
**Axetris AG, Switzerland**  
Schwarzenbergstrasse 10  
CH-6056 Kaegiswil  
Switzerland  
phone: +41 41 662 76 76  
fax: +41 41 662 75 25  
axetris@axetris.com  
www.axetris.com

**USA:**  
**Leister Technologies LLC**  
1275 Hamilton Parkway  
Itasca, IL 60143  
United States  
phone: +1 630 760 1000  
fax: +1 630 760 1001  
axetris.usa@axetris.com  
www.axetris.com

**China:**  
**Leister Technologies Ltd.**  
Building 11, 155 Yuanke  
Road  
Xinzhuang Industry Park  
Shanghai 201109 PR China  
phone: +86 21 6442 2398  
fax: +86 21 6442 2338  
axetris@axetris.cn  
www.axetris.cn

**Japan:**  
**Leister Technologies KK**  
Shinyokohama Bousei Bldg  
1F  
3-20-12, Shinyokohama,  
Kohoku-ku  
Yokohama 222-0033 /  
Japan  
phone: +81 45 477 36 37  
fax: +81 45 477 36 38  
axetris@axetris.jp  
www.axetris.jp

**Swiss Made Quality.** Axetris is an **ISO 9001** certified enterprise. Specifications are subject to change without prior notice

## 7 Important Notice / Disclaimer

The information furnished by Axetris is believed to be correct and accurate. However, Axetris shall not be held liable to recipient or any third party of any damages, including but not limited to personal injury, property damage, loss of profits, loss of use, interrupt of business or indirect, special incidental or consequential damages, of any kind, in connection with or arising out of the furnishing, performance or use of technical data herein. No obligation or liability to recipient or any third party shall arise or flow out of Axetris rendering of technical or other services. While due caution has been exercised in the production of this document, possible errors and omissions are unintentional.

## 8 Axetris Certifications

Axetris is an ISO 9001 certified company. The LGD F200P2 H module is CE and RoHS 2 compliant.



**CLASS 1 LASER PRODUCT**  
(classified according to SN EN 60825:1:2014)