

# SPECIFICATION

**Product Name: Super Low Power Industrial Grade  
NDIR Gas Sensor**

**Item No.: SRH-SL, SJH-SL, SBH-SL Series**

**Version: V0.2**

**Date: January 30, 2024**

# Revision

No.	Version	Content	Date
1	V0.1	Preliminary version	2023-08-18
2	V0.2	1. Response time updated to <10s; 2. Average working current updated to 1.5mA and peak current updated to 4mA.	2024-01-30

# Super Low Power Industrial Grade NDIR Gas Sensor

## SRH-SL, SJH-SL, SBH-SL Series



### SRH-SL Series

#### Application

- Carbon dioxide gas leakage alarming
- CO<sub>2</sub> incubator
- Greenhouse
- Controlled-atmosphere (CA) storage, cold-chain
- MAP (modified atmosphere packaging) storage
- Underground garage
- Hydroponic culture



### SJH-SL Series

#### Application

- Mine, metallurgy, oil & gas
- LNG gas leakage alarming
- Gas concentration meter
- Organic solvent
- Liquefied gas station
- Fuel gas transport



### SBH-SL Series

#### Application

- Mine, metallurgy, oil & gas
- Gas leakage alarming
- LPG leak monitoring
- Refrigerant leak sensor
- Liquefied gas station
- Fuel gas transport

## Description

Super low power industrial grade NDIR gas sensors are adopted non-dispersive Infrared (NDIR) technology, made by advanced technology and elements, so they have splendid features and are widely used to detect concentration of CO<sub>2</sub>, CH<sub>4</sub>, C<sub>3</sub>H<sub>8</sub> in both industry and agriculture applications.

Super low power industrial grade NDIR gas sensors can be easily integrated in safety and alarming devices, able to be used for intelligent agriculture, industrial safety, environmental monitoring, gas drainage pipes monitoring and other situations for CO<sub>2</sub>, CH<sub>4</sub>, C<sub>3</sub>H<sub>8</sub> such as chemical industry, petroleum, metallurgy, oil depot, liquefied gas station, gas transmission and distribution.

## Main Features

- ◇ For detection of the following gases:
  - Carbon Dioxide (SRH-SL series),
  - Methane (SJH-SL series),
  - Propane (SBH-SL series)
- ◇ Multi-measurement range, with full range linearized and digital signal output
- ◇ Super low power for battery powered devices
- ◇ Build-in/Embedded temperature and humidity compensation and matrix calibration to ensure accuracy
- ◇ High humidity alert mechanism, reliable fail-safe operation
- ◇ Auto zero-calibration mechanism available
- ◇ Fast response, no moving parts, high stability, anti-corrosion
- ◇ Multiple size options for different applications
- ◇ Meet the explosion-proof level Ex ia IIC T4 Ga

## Principle of Measurement

### Non-Dispersive Infrared (NDIR) Principle

Molecules like CO<sub>2</sub> and CH<sub>4</sub> are composed of different types of atoms, they have an absorption spectrum in the infrared range. Absorption intensity follows Lambert-Beer's Law. When a light wave corresponding to a certain gas with an absorption spectrum passes through the measured gas, the intensity of the light wave will be significantly weakened. The intensity attenuation is related to the concentration of the measured gas. This relation follows Lambert-Beer's Law. The basic working principle of an NDIR sensor is as follows.

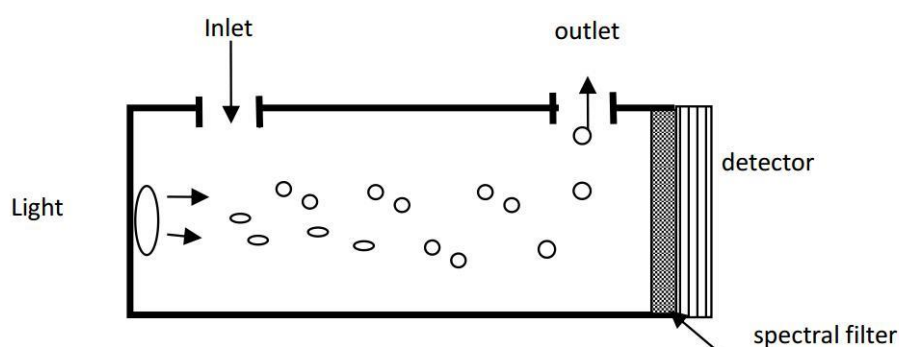

Basic mathematical model: A majority of both organic and inorganic polyatomic gases have specific absorptive wavelengths in the infrared region. When infrared light passes through, the light transmissivity of this gas molecule to a certain wavelength can be expressed by Lambert-Beer's Law:

$I$  stands for light transmissivity,  $I = I_0 e^{-kpl}$

$i$  stands for light absorption intensity,  $i = I_0 - I = I_0 (1 - e^{-kpl})$

$I_0$ : incident light intensity.

$l$ : thickness of gaseous medium

$p$ : gas concentration

$k$ : absorption coefficient

## Senser Types Guide

---

S   X   H - X   X - SL

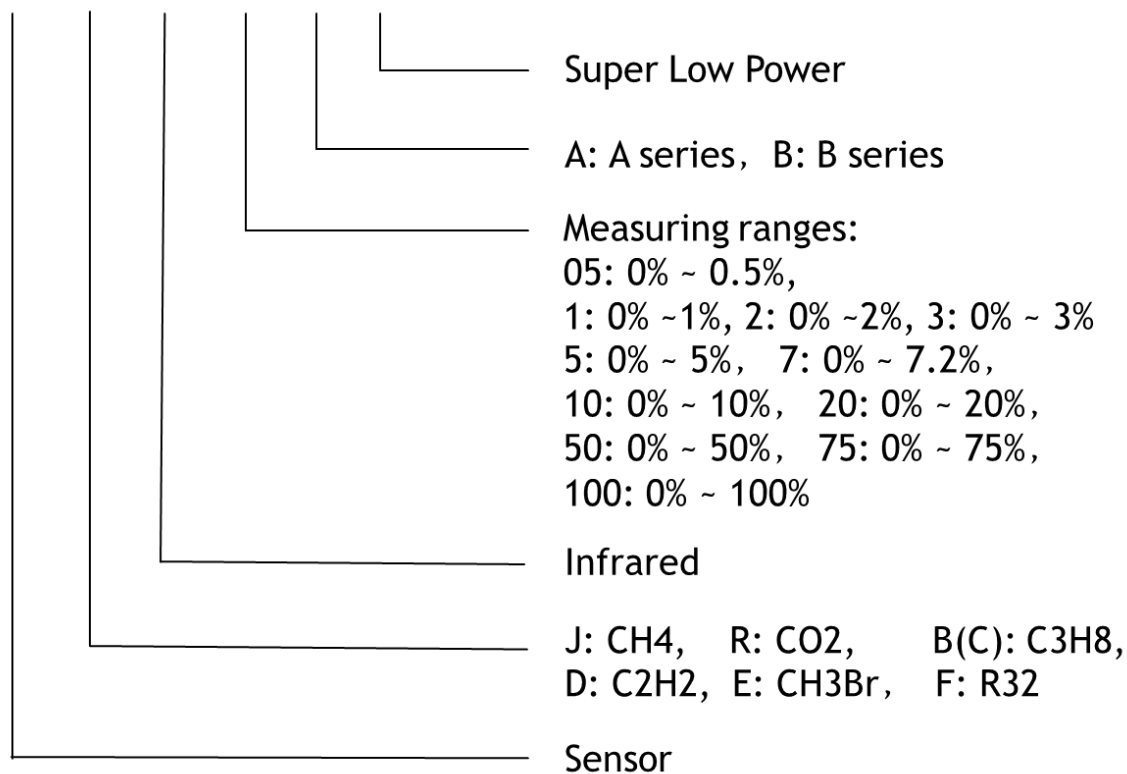

## Technical Parameters

### Configuration Table

Sensor Type	Gas	Concentration Range	Temperature or Humidity Compensation		Auto Baseline Calibration <sup>2</sup>	Sensor Dimension (mm)		QTY of Pins
			Temperature Sensor	Humidity Sensor <sup>1</sup>		Φ20*16.6	Φ20*19	
SRH-05A-SL	Carbon Dioxide	0~5000ppm	√	√	√	-	√	5
SRH-05B-SL		0~5000ppm	√	√	√	√	-	5
SRH-1A-SL		0~1%Vol	√	√	√	-	√	5
SRH-1B-SL		0~1%Vol	√	√	√	√	-	5
SRH-2A-SL		0~2%Vol	√	√	√	-	√	5
SRH-2B-SL		0~2%Vol	√	√	√	√	-	5
SRH-5A-SL		0~5%Vol	√	√	√	-	√	5
SRH-5B-SL		0~5%Vol	√	√	√	√	-	5
SRH-10A-SL		0~10%Vol	√	√	√	-	√	5
SRH-10B-SL		0~10%Vol	√	√	√	√	-	5
SRH-20A-SL		0~20%Vol	√	√	√	-	√	5
SRH-20B-SL		0~20%Vol	√	√	√	√	-	5
SJH-5A-SL	Methane	0~5%Vol	√	√	√	-	√	5
SJH-5B-SL		0~5%Vol	√	√	√	√	-	5
SJH-100A-SL		0~100%Vol	√	√	√	-	√	5
SJH-100B-SL		0~100%Vol	√	√	√	√	-	5
SBH-2A-SL	Propane	0~2%Vol	√	√	√	-	√	5
SBH-2B-SL		0~2%Vol	√	√	√	√	-	5
SBH-5A-SL		0~5%Vol	√	√	√	-	√	5
SBH-5B-SL		0~5%Vol	√	√	√	√	-	5

Note:

1. Humidity sensors have high humidity alert mechanism: when relative humidity>95%, high humidity abnormality alert is triggered and concentration output will be 0; when relative humidity drops back to <90%, high humidity abnormality alert quits, sensor will recover back to normal working mode.

2. ABC (Auto Baseline Calibration) is off as default, it could be activated by communication protocol. For ABC function please contact Cubic.

## Technical Specification

Sensor Type <sup>1</sup>	SRH-05A-SL SRH-05B-SL	SRH-1A-SL SRH-1B-SL	SRH-2A-SL SRH-2B-SL	SRH-5A-SL SRH-5B-SL	SRH-10A-SL SRH-10B-SL	SRH-20A-SL SRH-20B-SL	SJH-5A-SL SJH-5B-SL	SJH-100A-SL SJH-100B-SL	SBH-2A-SL SBH-2B-SL	SBH-5A-SL SBH-5B-SL
Gas	Carbon Dioxide						Methane		Propane	
Measurement Range	0~5000ppm	0~1%Vol	0~2%Vol	0~5%Vol	0~10%Vol	0~20%Vol	0~5%Vol	0~100%Vol	0~2%Vol	0~5%Vol
Accuracy <sup>2,3</sup>	±200ppm	±400ppm	0-1%:±≤0.1%Vol 1%-5%:± (0.05%+5% of reading) 5%-full range:± ±6% of reading				0-1%: ≤±0.06%Vol 1%-100%:≤±6% of reading		0-1%: ≤ ±0.06%Vol 1%-5%:≤ ±6% of reading	
Resolution (ppm)	1ppm		0.01% Vol							
Warm-up Time <sup>4</sup>	10s									
Maximum Response Time (T <sub>90</sub> )	<10s									
Zero Repeatability <sup>5</sup>	-						±0.01% Vol		±1%FS	
Full Scale Point Repeatability <sup>5</sup>	-						±0.03% Vol		-	
Zero Drift <sup>4</sup>	±3%FS/year									
Working Temperature	-40~70℃									
Storage Temperature	-40~85℃									
Working Humidity <sup>6</sup>	0-95%RH (Non-condensing)									
Power Supply	3.3~5.5VDC									
Working Current	Average: 1.5mA (5V power supply); Peak: 4mA (5V power supply)									
Working Pressure <sup>7</sup>	1. 30~130kPa 2. All data can be ensured at pressure 101 kPa									
Output Type	UART-TTL (2.5-3.3V) /DA output (0.4-2V)									
Dimension	Refer to Configurations Table									
Body material	Stainless Steel									
Weight <sup>8</sup>	<20g									
Life Span <sup>9</sup>	≥ 10 years									
Ex-proof Level	Ex ia IIC T4 Ga									

- Sensor type A is the sensor with dimension Φ20 x 19mm (Except Pin), others is Φ20 x 16.6mm (Pins are not included).
- The standard gas sample is provided by the party certified by the China National Metrology Department. All gases diluted in dry nitrogen; the purity of dry nitrogen greater than 99.999%.
- Performance defined above is after calibration. All Cubic sensor have 100% calibration in production.
- Continuous operation at ambient temperature (20℃)
- After sensor stabilization over a period of 8 hours and ambient temperature (20℃)
- Humidity sensors have high humidity alert mechanism: when relative humidity>95%, high humidity abnormality alert is triggered and concentration output will be 0; when relative humidity drops back to <90%, high humidity abnormality alert quits, sensor will recover back to normal working mode.
- Sensors shall meet specification within a±5% change in ambient pressure from the ambient pressure during calibration, Sensors can be used over a larger ambient pressure with pressure compensation, in this case, an external pressure sensor shall be used.
- Weight of sensor type A is 18g; weight of sensor type B is 15.6g.
- Based on light source life time at continuous operation scenario.

# Configuration Pin Definition

## 1. Appearance Size

**SXH-XA-SL Type Sensor Height: 19mm (See Configuration Table)**

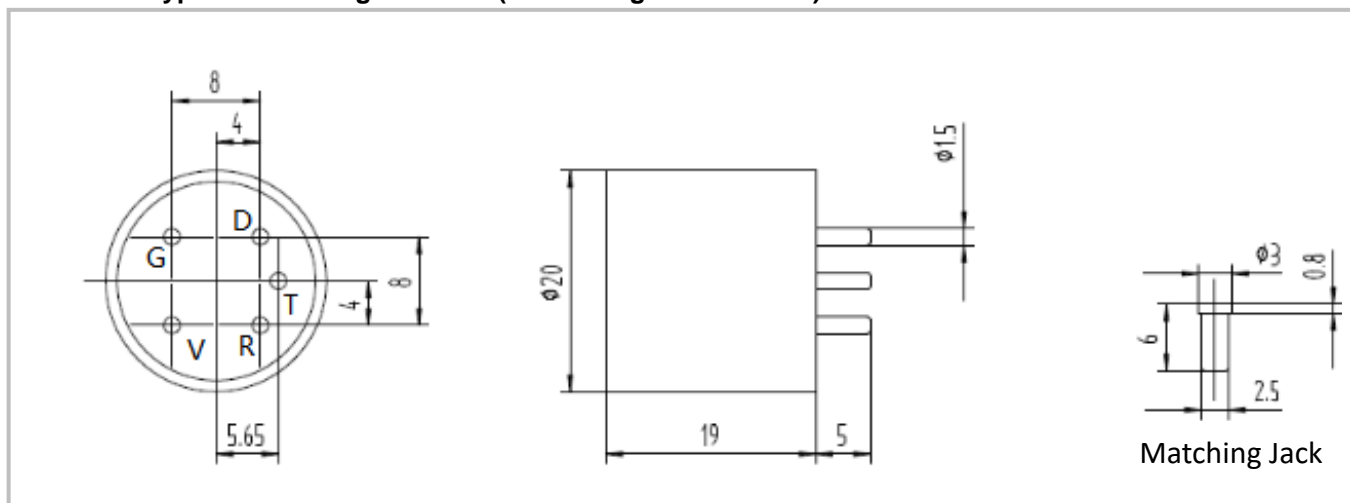

**SXH-XB-SL Type Sensor Height 16.6mm (See Configuration Table)**

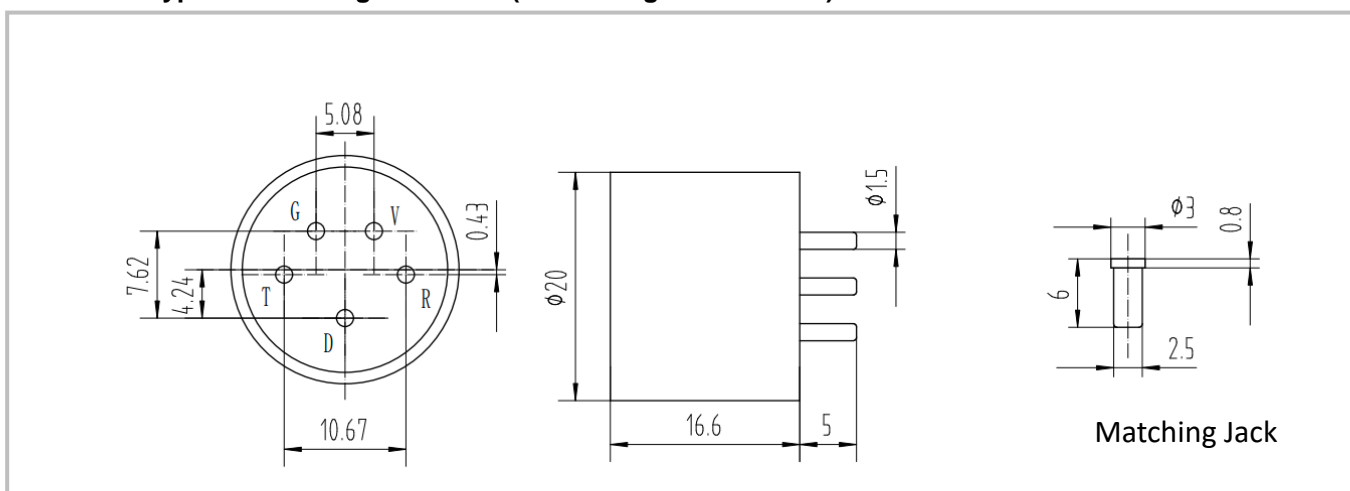

## 2. Pin Definitions

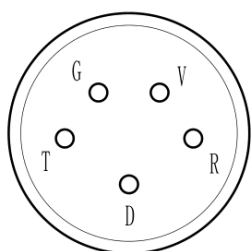

Pin	Name	Description
V	Vi	Power Input (Vi: DC3.3V~5.5V, Recommend Vi=5V)
G	GND	Power Input Terminal (Ground Terminal)
T	TX	Serial Port Terminal (Circuit Board Serial Port Sender)
D	Vout	Voltage Output Terminal
R	RX	Serial Port Terminal (Circuit Board Serial Port Receiver)

### Appearance Size Notes

1. All dimensions in unit of millimeters;
2. Body dimensional tolerances  $\pm 0.2$  mm.



## Typical Application Circuit Diagram

### Application Scenario 1: UART Serial Port Output

External devices can communicate with sensors through UART.

3.3V device (CPU) can be connected with serial port pin RX and TX directly.

The interface circuit is as follows, reading gas concentration data or performing calibration function.

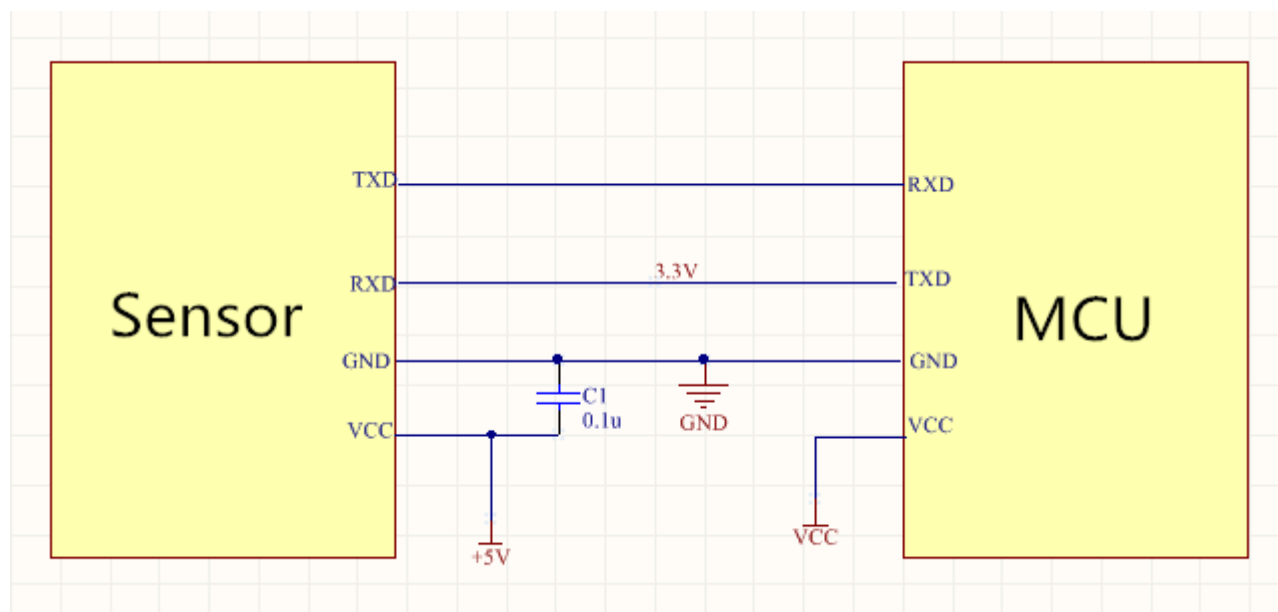

**Picture 1:** UART Communication Connecting Circuit

## Typical Application Circuit Diagram

### Application Scenario 2: UART-TTL to RS232

When connecting external circuit, computer circuit is illustrated below:

Baud Rate: 9600bps

Data Bit: 8

Stop Bit: 1

Check Bit: null

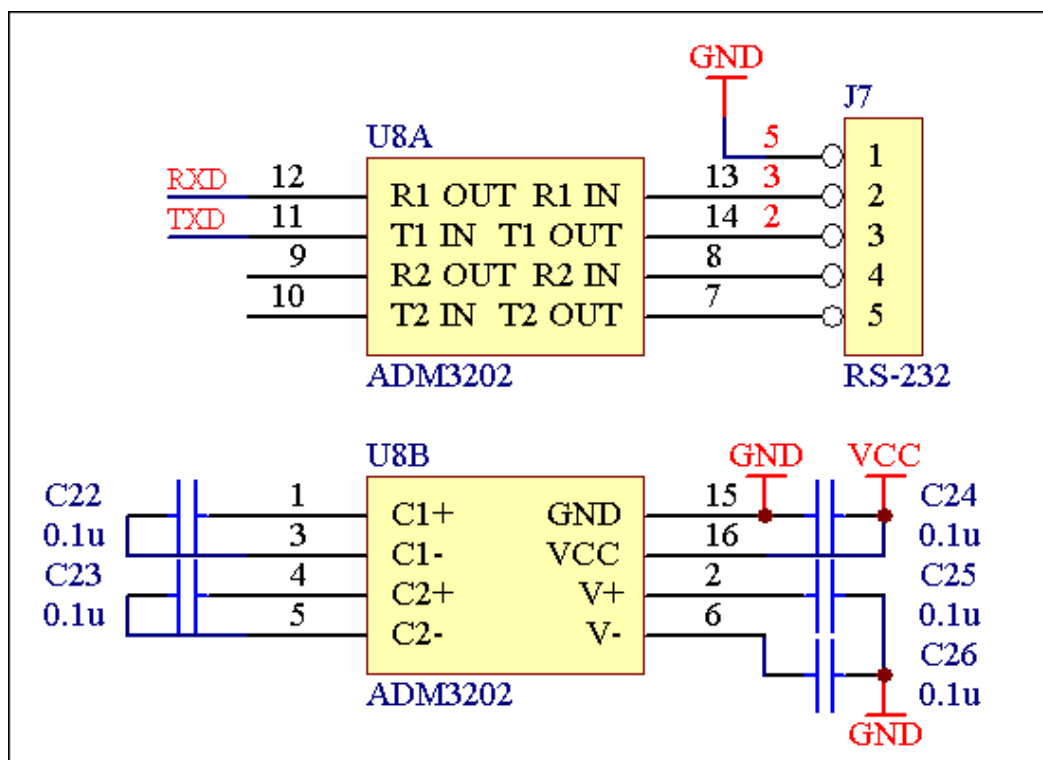

Picture 2: UART-TTL to RS232 Circuit

## Typical Application Circuit Diagram

### Application Scenario 3: 5V-2.5V Level Switching Circuit

Sensor needs to transform the voltage when connecting with 5V devices,

the interface circuit is as follows:

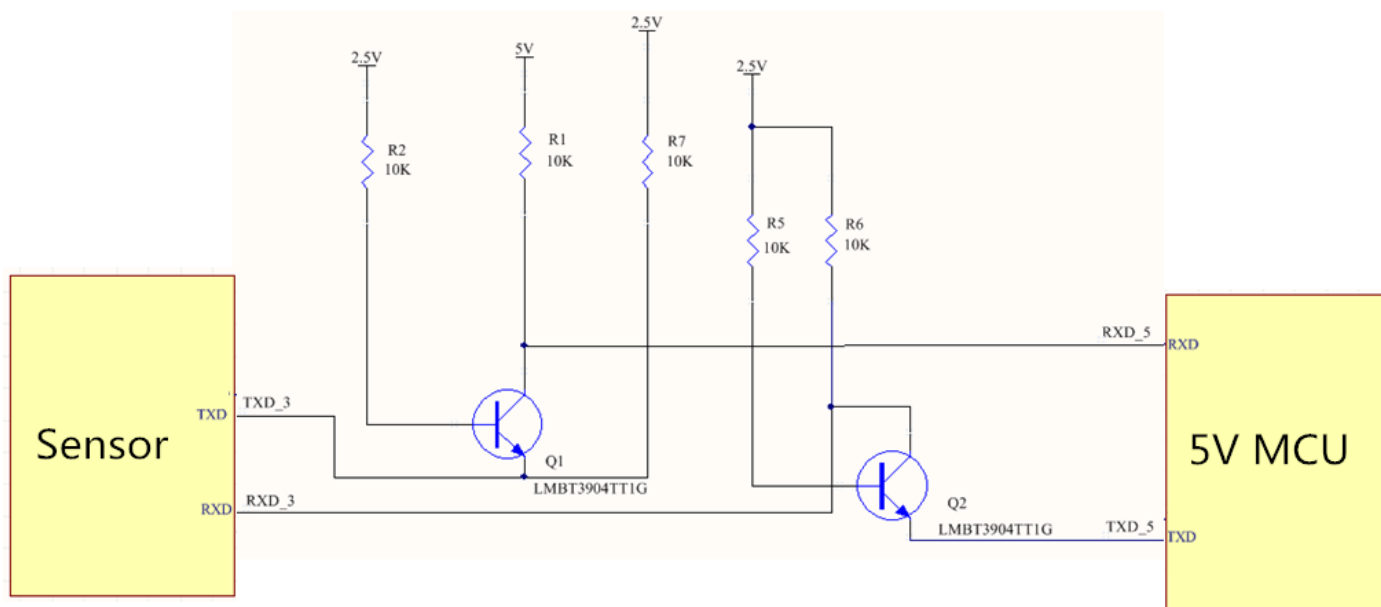

**Picture 3:** 2.5V Communication Level Converted to 5V Communication Level Circuit

## Typical Application Circuit Diagram

### Application Scenario 4: Voltage Output

Sensor Pin D (Vout) output signal is 0-2.5V DC voltage, where 0.4-2.0V corresponding to 0-100% full range gas, the user can convert the voltage signal to industrial standard 4-20mA current signal through voltage current converter.

The interface circuit is as follows:

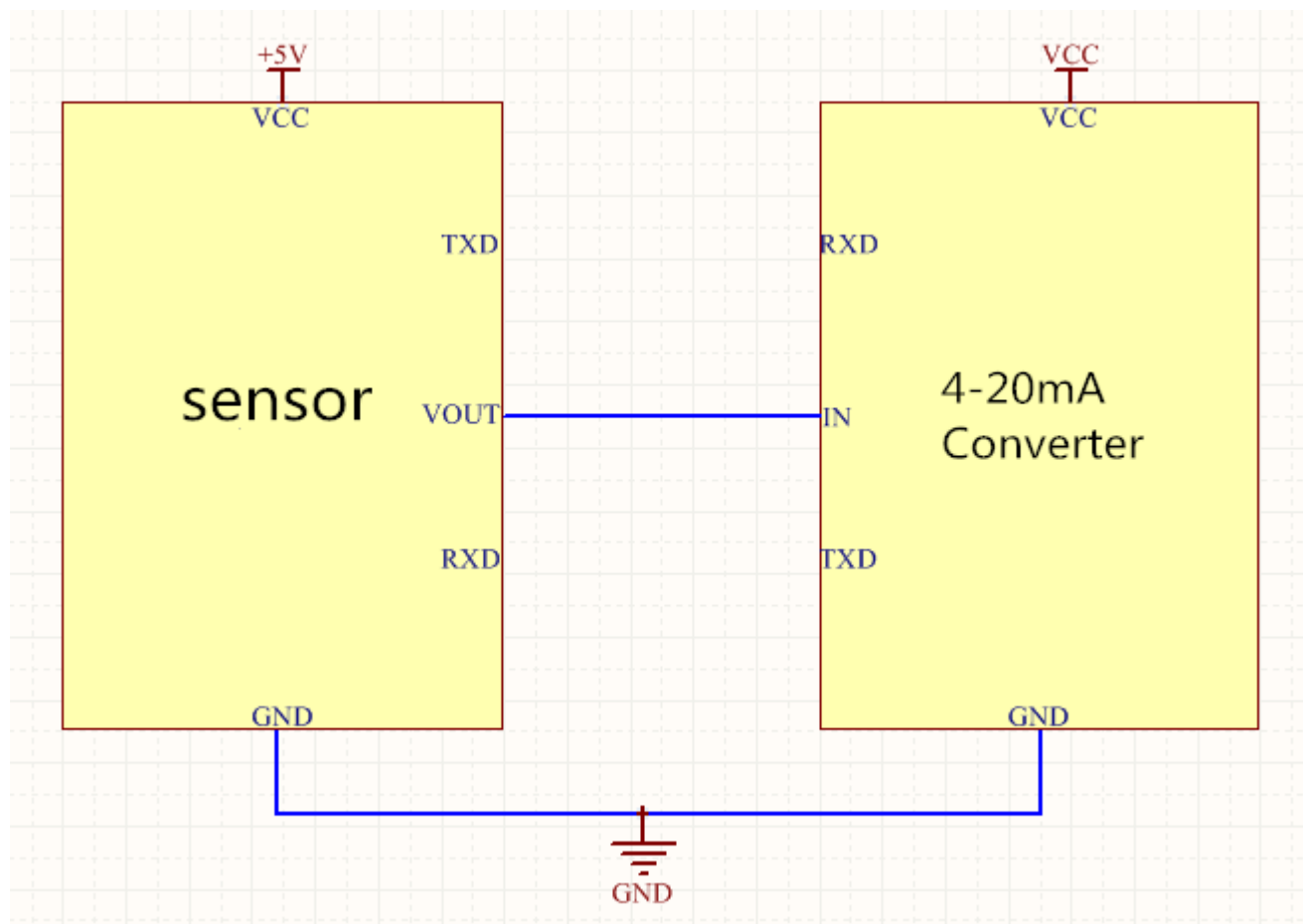

**Picture 4:** Analogue signal output circuit

## Precautions for Use

---

1. Working temperature: - 40°C ~ 70°C
2. The connecting cable shall be shielded cable with insulating sheath, and its shielding layer shall be grounded.
3. Users should not replace the components of this product without authority. To avoid damaging product, please kindly solve the problems in operation with our engineers.
4. Installation, use and maintenance of this product should comply with relevant provisions of product instruction,  
GB3836.13-1997 "Electrical equipment for explosive gas environment Part 13: Explosion Overhaul of electrical equipment for explosive gas environment ",  
GB3836.15-2000 "Explosive gas environmental electrical equipment Part 15: Electrical installation in hazardous places (coal) Mine)",  
GB3836.16-2006 "Explosive Gas Environmental Electrical Equipment Part 16: Inspection and maintenance of electrical installations (except coal mines)",  
GB50257-1996 "Electrical installation engineering explosion and fire hazard environment Electrical installation and acceptance specifications".

# Communication Protocol

---

## 1. General Statement

1. Baud rate: 9600bps, DataBits:8, StopBits:1 Parity: No, Flow Control: No
2. All data in this protocol is in hexadecimal, for instance [46] stands for decimal "70".
3. [xx] is an unsigned single-byte data (from 0 to 255); (xx) is a signed double-byte data (from -32768 to +32767), with high-order byte ahead of low-order byte (Big-Endian).
4. The entire command length is [LB]+3 bytes.

## 2. Communication Protocol Format

**Send:** [IP] [LB] [CMD] [DF] [CS]

- [IP] address (fixed as 11)
- [LB] length of the bytes followed; CS excluded.
- [CMD] command
- [DF] arguments of the command, optional
- [CS] check sum,  $CS = 0x100 - \{IP + LB + CMD + DF\}$

### Response:

1. When the command is correctly executed, it responds

[ACK] [LB] [CMD] [DF] [CS]

[ACK] = 0X16 command is correctly executed

- [LB] length of the bytes followed; CS excluded.
- [CMD] command
- [DF] arguments of the command, optional
- [CS] check sum,  $CS = 0x100 - \{ACK + LB + CMD + DF\}$

2. When the command is not correctly executed, it responds

[NAK] [LB] [CMD] [EC] [CS]

[NAK] = 0X06 command is not correctly executed

- [LB]=2 length of the bytes followed; CS is excluded.
- [CMD] command
- [EC] error codes when the command is not correctly executed
- [CS] check sum,  $CS = 0x100 - \{NAK + LB + CMD + DF\}$

Error codes [EC] description as below:

- 01 Check sum error.
- 02 The command is not correct.
- 03 Can't executed this command under current status.

### 3. Function List

Number	Function Name	CMD	Function Description
1	Check the Measurement Result	0x01	
2	Single Point Calibration	0x03	
3	User Calibration	0x4B, 0x4C, 0x4E	Used for Gas Calibration
4	Reset to Factory Calibration Data	0x4D	
5	Check the Software Version	0x1E	
6	Check the Serial Number of the Instrument	0x1F	
7	Check the Gas Measurement Property	0x0D	

### 4. Detailed Description

#### 1. Check the Measurement Result

**Send:** 11 01 01 ED

**Response:** [ACK] 05 01 [DF1] [DF2] [ST1] [ST2] [CS]

**Function:** check the measurement result

**Remark:**

1. Gas 1 concentration =  $(DF1*256+ DF2) / 10^n$

NOTE: The value n depends on the sensor's resolution. If the resolution is 0.01%, then n = 2. If the resolution is 1ppm, then n = 0. For instance:

- The resolution of an SJH-5A-SL type sensor is 0.01%, therefore its concentration =  $(DF1*256+ DF2) / 10^2 = (DF1*256+ DF2) / 100$ .
- The resolution of an SRH-05A-SL type sensor is 1ppm, therefore its concentration =  $(DF1*256+ DF2) / 10^0 = DF1*256+ DF2$ .

2. [ST1] Sensor working status, definition is shown in the following table:

BIT0	<b>Sensor Warm-up Status</b> 1 Sensor is warming-up, concentration output is zero in 10s period of warming-up time. 0 Warm-up completed; output is normal concentration data.
BIT1	<b>Sensor Malfunction Status</b> 1 Malfunction, concentration output is forced to 0. 0 Signal is normal, no malfunction. Sensor malfunction determination method: reference AD or measuring AD < 800, too low signal is considered a sensor failure.
BIT2	<b>Sensor Display Value Out of range Status</b> 1 Sensor concentration display value exceeds the range. 0 Sensor concentration display value is within the display range.
BIT3	<b>Negative Value Flag</b> 1 Value of concentration is negative; however, it is limited to 0 when displayed. 0 Value of concentration is positive.
BIT4	<b>Sensor Calibration Status</b> 1 No calibration, concentration output is forced to 0. 0 Sensor calibrated
BIT5	<b>Sensor High Humidity Alarm Status</b> 1 High humidity, concentration output is forced to 0.

	0 The sensor works within the normal humidity range. When relative humidity>95%, BIT5=1, concentration output is forced to 0; when relative humidity drops to <90%, quit high humidity alarm, sensor work normally, BIT5=0.
BIT6	<b>Sensor Reference Channel Display Value Over Limit Status</b> 1 Reference channel display value over limit, sensor malfunctions. 0 Reference channel display value within limit.
BIT7	<b>Sensor Measurement Channel Display Value Over Limit Status</b> 1 Measurement channel display value over limit, sensor malfunctions. 0 Measurement channel display value within limit

3. [ST2] reserved.

## 2. Single Point Calibration

**Send:** 11 03 03 [DF1] [DF2] [CS]

**Response:** [ACK] 01 03 [CS]

**Function:** single point calibration of the sensor's concentration

### Remark:

1. Target value for single point calibration =  $(DF1*256+DF2)/10^n$

NOTE: The value n depends on the sensor's resolution. If the resolution is 0.01%, then n = 2. If the resolution is 1ppm, then n = 0. For instance:

- The resolution of an SJH-5A-SL type sensor is 0.01%, calibration concentration =  $(DF1*256+ DF2) / 10^2 = (DF1*256+ DF2) / 100$ .
  - The resolution of an SRH-05A-SL type sensor is 1ppm, calibration concentration =  $(DF1*256+ DF2) / 10^0 = DF1*256+ DF2$ .
2. Please ensure that the CO2 concentration is equal to the target value and the calibration is performed after the reading value of the sensor is stabilized.
3. For NDIR R32 sensors, the single point calibration command is 11 01 03 [CS] which is for zero-point adjustment with N2/Air.

### Examples:

- SRH-05A-SL calibration under air condition (CO2 concentration 400 ppm):  
host send: 11 03 03 **01 90** 58, sensor response: 16 01 03 E6
- SRH-05A-SL calibration under N2 condition (CO2 concentration 0 ppm):  
host send: 11 03 03 **00 00** E9, sensor response: 16 01 03 E6
- SJH-5A-SL calibration under standard gas condition (CH4 concentration 1.00% vol):  
host send: 11 03 03 **00 64** 85, sensor response: 16 01 03 E6

## 3. User Calibration

**Send:** 11 04 [CMD] 00 [DF1] [DF2] [CS]

**Response:** [ACK] 01 [CMD] [CS]

**Function:** User calibration

### Remark:

(1) [CMD] list:

No.	CMD	Function
1	<b>0x4B</b>	Zero-point calibration
2	<b>0x4C</b>	Full scale calibration
3	<b>0x4E</b>	Middle point calibration

(2) calibration gas concentration =  $(DF1*256+ DF2) / 10^n$



NOTE: The value n depends on the sensor's resolution. If the resolution is 0.01%, then n = 2. If the resolution is 1ppm, then n = 0. For instance:

- The resolution of an SJH-5A-SL type sensor is 0.01%, calibration concentration =  $(DF1*256+ DF2) / 10^2 = (DF1*256+ DF2) / 100$ .
- The resolution of an SRH-05A-SL type sensor is 1ppm, calibration concentration =  $(DF1*256+ DF2) / 10^0 = DF1*256+ DF2$ .

(3) User calibration shall be carried out on the condition that the sensor could not be able to reach all the accuracy requirements after it has been done a single point calibration. Make sure that the corresponding standard gas and environment condition are ready before executing the user calibration command. Be sure that the ambient temperature is stable and the sensor has been continuously powered for minimum 30 minutes. Pass through gas with the corresponding concentration and wait until the reading value of the sensor (by sending 11 01 01 ED command) stabilize before sending this command. Other calibration points should be finished after one calibration point has been done. Incomplete user calibration will lead to abnormal accuracy.

(4) User calibration command should be operated cautiously which will lead to abnormal measurements of the sensor if mis-operated. In case of abnormal measurement, please recalibrate the sensor as per step (3) above or running the "Reset Factory Calibration Data" command.

(5) Suggested calibration points for SJH-SL/SRH-SL/SBH-SL

No.	Sensor Type	Concentration at Zero-point calibration	Concentration at full scale calibration	Concentration at middle point calibration
1	SJH-5X-SL	0	5.00%	No need for calibration
2	SJH-100X-SL	0	100.00%	5.00%
3	SRH-05X-SL	0	5000ppm	No need for calibration
4	SRH-1X-SL	0	10000ppm	No need for calibration
5	SRH-2X-SL	0	2.00%	No need for calibration
6	SRH-5X-SL	0	5.00%	No need for calibration
7	SRH-10X-SL	0	10.00%	No need for calibration
8	SRH-20X-SL	0	20.00%	5.00%
9	SBH-2X-SL	0	2.00%	No need for calibration
10	SBH-5X-SL	0	5.00%	No need for calibration

Examples:

No.	Sensor Type	Calibration command
1	SJH-5X-SL	Zero-point (0) calibration: 11 04 4B 00 00 00 A0 Full scale (5.00%) calibration: 11 04 4C 00 01 F4 AA
2	SJH-100X-SL	Zero-point (0) calibration: 11 04 4B 00 00 00 A0 Middle point (5.00%) calibration: 11 04 4E 00 01 F4 A8 Full scale (100.00%) calibration: 11 04 4C 00 27 10 68
3	SRH-05X-SL	Zero air (400ppm) calibration: 11 04 4B 00 01 90 0F Full scale (5000ppm) calibration: 11 04 4C 00 13 88 04
4	SRH-20X-SL	Zero-point (0) calibration: 11 04 4B 00 00 00 A0 Middle point (5.00%) calibration: 11 04 4E 00 01 F4 A8 Full scale (20.00%) calibration: 11 04 4C 00 07 D0 C8

#### 4. Reset to Factory Calibration Data

**Send:** 11 02 4D 00 A0

**Response:** 16 01 4D 9C

**Function:** Reset the user calibration data to factory calibration data and the single point calibration is cleared.

**Remark:** this command is used for factory restore after user calibration errors.

## 5. Check the Software Version

**Send:** 11 01 1E D0

**Response:** [ACK] [x+1] 1E [CH1] [CH2] [CH3] .....[CHx] [CS]

**Function:**

**Remark:**

Output the version number of software.

[CH1] - [CHx] is the version of software, which shows as ASCII code.

## 6. Check the Serial Number of the Sensor

**Send:** 11 01 1F CF

**Response:** [ACK] 0B 1F (SN1) (SN2) (SN3) (SN4) (SN5) [CS]

**Function:**

**Remark:**

Output the serial number of the instrument.

SNn range is 0~9999, the five integer numbers form a 20-digit number.

## 7. Check the Gas Measurement Property

**Send:** 11 01 0D E1

**Response:** [ACK] 08 0D [DF1] [DF2] [DF3] [DF4] [DF5] [DF6] [DF7] [CS]

**Function:** check the measurement range, decimal number and unit of the gas.

**Remark:**

(1) Measurement range =  $([DF1] * 256 + [DF2]) / 10^{[DF3]}$

(10<sup>[DF3]</sup> means the corresponding multiple that determined by the decimal places number [DF3] value)

(2) Decimal places = DF3

(3) [DF4]: reserved

(4) [DF5]: Unit of the output 0: ppm 2: Vol%

(5) [DF6] [DF7]: reserved

## After-sales Services and Consultancy

---

**Cubic Sensor and Instrument Co.,Ltd**

**Add:** Fenghuang No.3 Road, Fenghuang Industrial Park, Eastlake Hi-tech Development Zone, Wuhan 430205, China

**Tel:** 86-27-81628827

**Web:** [www.gassensor.com.cn](http://www.gassensor.com.cn)

**E-mail:** info@gassensor.com.cn